

Installation Instructions: Fire Exit push Pad or Push Bar (internal) with Outside Exit Device

1

Install night latch mechanism with 2 screws (To alternate between Left or Right swinging doors, push spring loaded latch & rotate 180° using a screwdriver as shown).

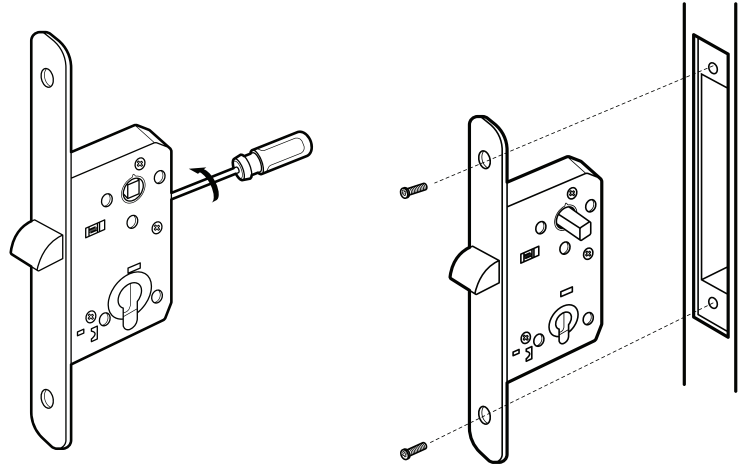

2

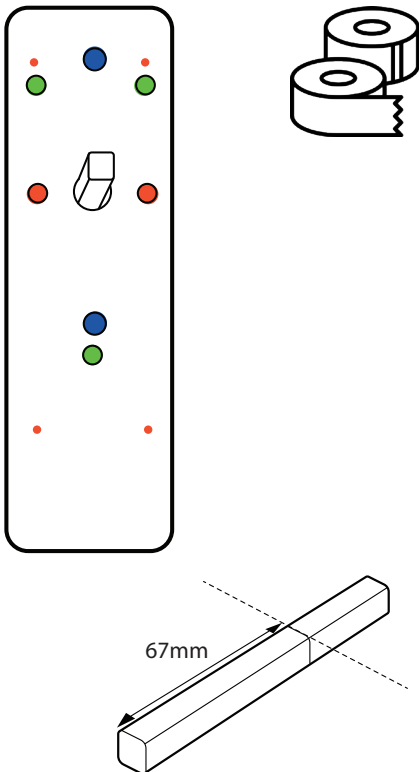

To fit Push Pad/Bar lever, cut the spindle to 67mm. Insert into place & place over template on the Exterior of the door. Ensure level/square & apply masking tape to secure.

3

Locate the fixing holes marked in on the template for your selected device (Blue is for Briton Outside Exit Device). Mark holes & carefully drill through exterior skin using an 8mm drill bit. Repeat on Interior ensuring holes align.

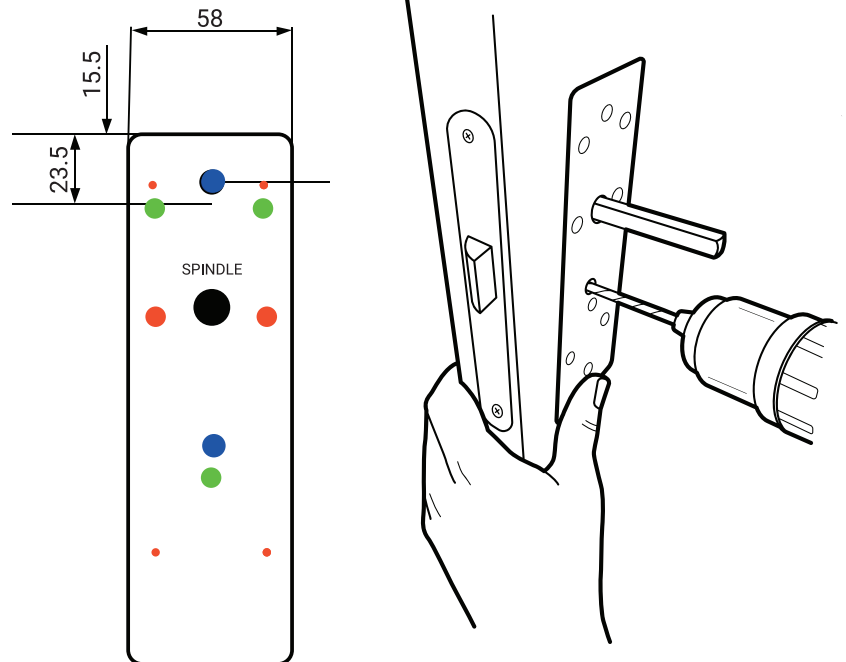

The Briton Outside exit device contains a tab (H6) on the lower back plate. Mark (cut & use Briton paper template if required) & drill hole in position of the tab using 8mm drill bit on the EXTERIOR face only

Installation Instructions: Fire Exit push Pad or Push Bar (internal) with Outside Exit Device

4

Attach knob or lever to the outside exit device using screw provided.

Hand tighten only.

The spindle direction needs to be set by rotating.
The direction arrow should be in the 3 o'clock position.

Once set, insert spindle & place onto exterior of the door, pushing firmly until flush.

Rotate the external knob / lever several times to ensure the latch opens fully releasing door cleanly. Only when satisfied, move onto the next step.

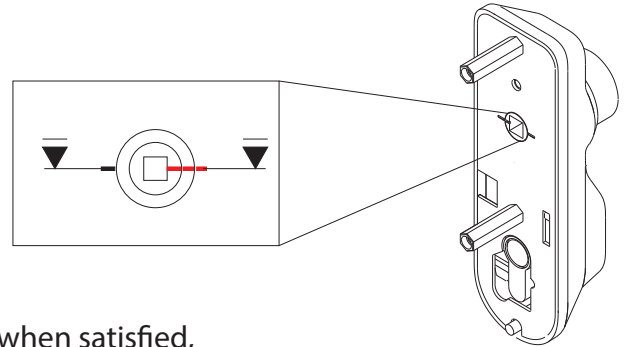

5

Cut the 2 x 5.5mm machine screws supplied with the Briton Exit Device handle to 35mm & screw into the outside exit device by hand to secure (ENSURE the metal template remains in position internally & secured by screws).

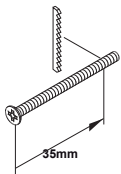

Rotate the external knob / lever several times to ensure the latch opens fully. If not, loosen, adjust handle placement & tighten screws until opens satisfactorily.

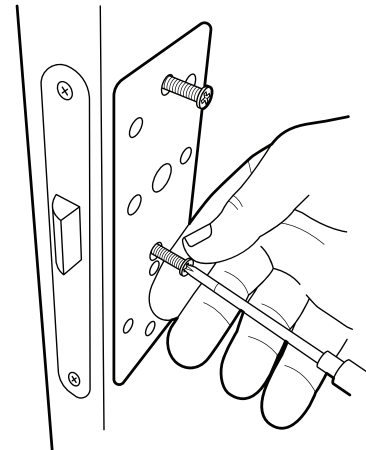

6

Take the Push Pad or Push bar lever.

Looking at the back plate, ensure set correctly for Left or Right opening which can be seen with an L or R on the spindle holder.

L is for left hinged doors viewed internally.

R is for Right hinged doors viewed internally.

(To alternate between L/R refer to Briton instruction manual)

The L/R Marking must be in the 6 o'clock position.

Once satisfied, push firmly over spindle tight to the template, & press/depress lever several times to ensure the latch opens fully satisfactorily.

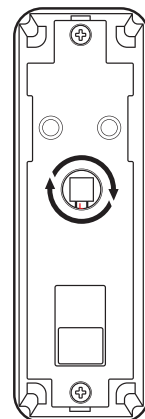

Installation Instructions: Fire Exit push Pad or Push Bar (internal) with Outside Exit Device

7

Once satisfied use the 4 x 45mm self drilling screws to secure the push pad into position. Note, Do not over tighten.

OPTIONAL: If using Briton push bar 379.N.SE instead, the push bar will need to be cut to suit the door leaf width (42mm smaller than door leaf).

Once cut, level & mark the 2nd lever ensuring minimum 15mm gap from to the door frame. Ensuring level, fix the 2nd lever in position using 4 x 45mm self drilling screws.

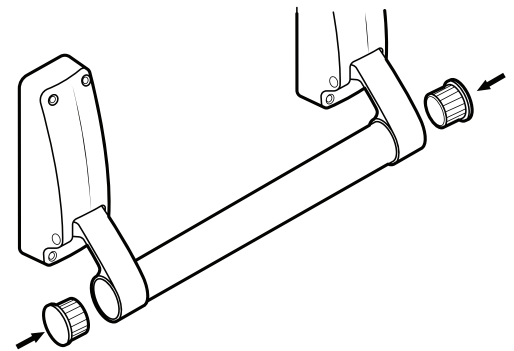
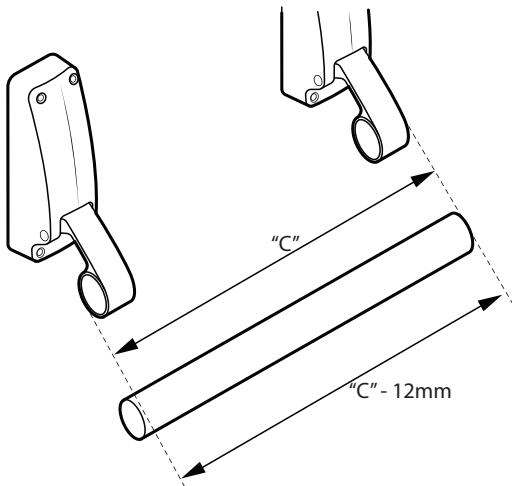
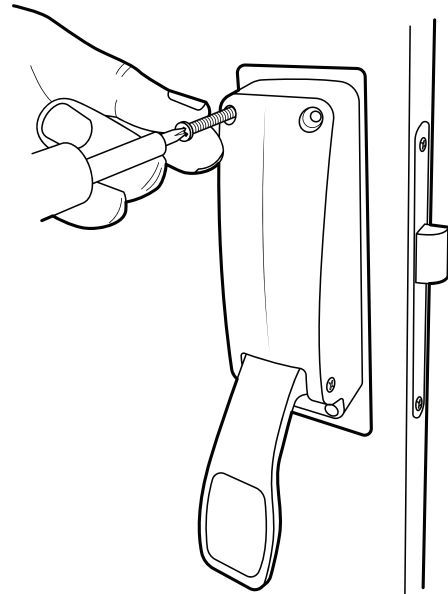

Test several times by closing and fully engaging the push pad to release. Apply vinyl signage as necessary (sold separately).

FINAL CHECKS

Panic exit devices must be fitted to comply with the requirements of EN 1125 which states that the device should be easily operated by hand or body pressure in a panic situation. We suggest the following checks be made on all panic and emergency exit hardware:

- Check that the door has not become distorted in any way. If the door does not meet the frame stops and cannot be pulled in by the door closer the door may need to be replaced.
- Check that the door hinges are operating smoothly and lubricate if necessary.
- Check that the latches are operating freely. If necessary remove the end box covers and/or pullman latch covers and lubricate if necessary.
- Check that all fixings are tight.

MONTHLY CHECKS

Inspect and operate the device to ensure all the components are in satisfactory working condition and operate as follows:

- a. After being pushed the 'Push bar' or 'Push Pad' should return automatically to its initial position.
- b. When pushed from the end casing side (hinge side of door) the latchbolt(s) should completely withdraw from their strikes as if it were pushed from the main casing side.

IMMEDIATE EXIT MUST BE PERMITTED.

- c. With the door closed, the latchbolts should be fully engaged into their strikers. They should not withdraw if pushed but should only withdraw if operated by the 'Push bar'.

TEMPLATE COVER PLATE FOR INSTALLATION OF FIRE EXIT PUSH PAD / OUTSIDE ACCESS DEVICE / EXTERNAL BLANKING PLATES

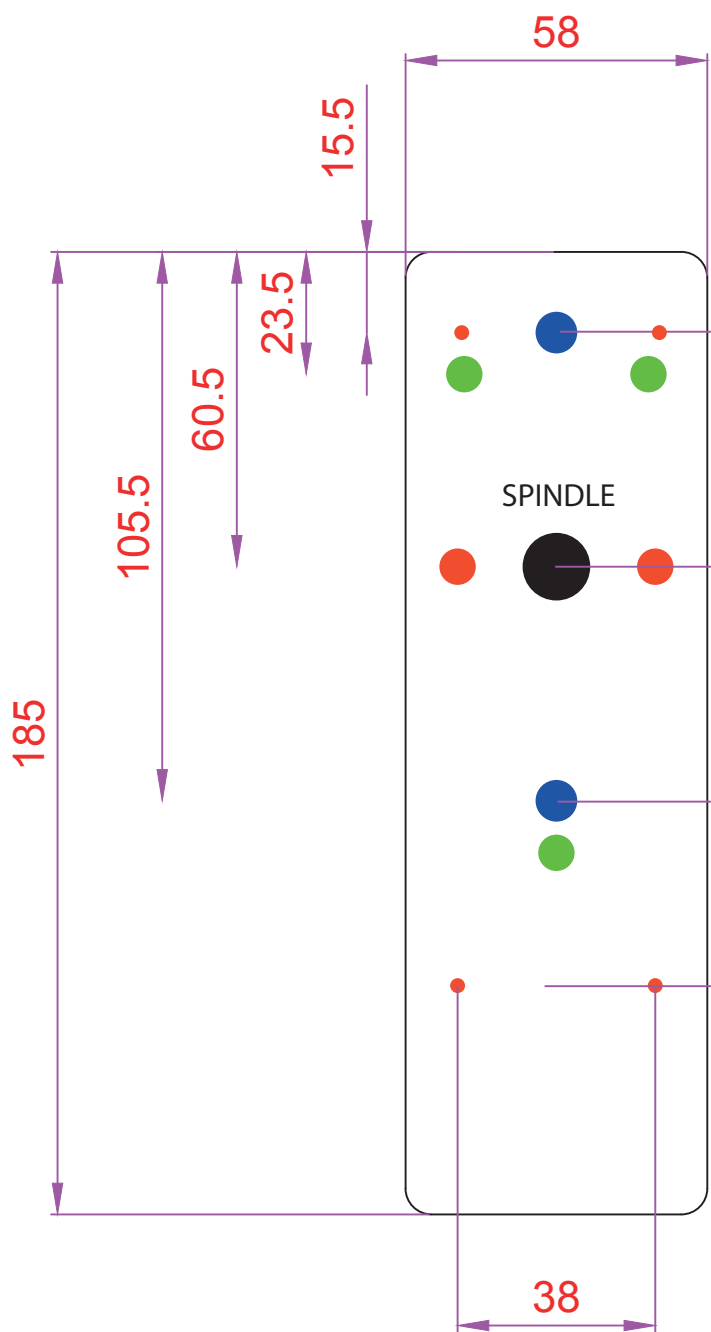

8MM HOLE TO SECURE BRITON1413 OUTSIDE ACCESS DEVICE (requires drilling of door with 8mm drill bit)

8MM HOLE TO FOR HANDLE/ESCUTCHEON OR EXTERNAL DOOR BLANK

8MM HOLE TO SECURE BRITON1413 OUTSIDE ACCESS DEVICE (requires drilling of door with 8mm drill bit)

1MM GUIDE HOLE FOR SELF DRILLING SCREWS (ONLY IF OUTSIDE ACCESS DEVICE IS FITTED)

OR
DRILL TO MAKE 8MM HOLE IF FITTING AN EXTERNAL BLANK

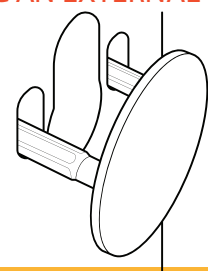

Steel Security Door – Operations & Maintenance Manual

The door assemblies consist of various components, each presenting unique maintenance considerations. We recommend performing maintenance on the doors and associated hardware every two months. This schedule can be adjusted after the initial visit, based on actual usage.

Proper maintenance of all components is crucial; neglecting any part can lead to premature wear or malfunction. For example, a door blade may appear undamaged, but if the panic hardware is untested, it could pose a safety risk.

Please note that all doors come with a manufacturer's warranty (see terms and conditions for details). This warranty may be voided if maintenance is not performed as outlined in this manual.

Door Maintenance

Inspect door alignment every 6 months to ensure the door and frame are true. Doors should be free of dents and scratches and should operate smoothly. Regularly check door seals for proper fit and signs of damage.

Ensure doorways are free from obstructions to allow unimpeded operation. Daily visual inspections should be conducted to promptly identify any damage. Report any issues to the designated responsible person for timely resolution.

Locks and panic hardware must be checked for proper operation, and adjustments made as necessary. For any malfunctioning ironmongery, please contact us for assistance.

Latches & Hinges

Hinges should be installed accurately for optimal performance, with all hinge pins aligned vertically. Periodic inspections are necessary to check for wear that could hinder movement or cause the door to sag.

All screws should be tightened to prevent loosening, which is often caused by misalignment or improper screw choice. Loose screws should be addressed, either through tightening, realignment, or by using more suitable screws.

Lubricate hinges with light machine oil periodically. Squeaking indicates a need for lubrication, but frequent squeaks may suggest misalignment issues. For stainless steel hinges, dust regularly, wash with warm soapy water, and avoid abrasive cleaners. A light grease coating is recommended post-cleaning.

Correctly fitted locks and latches may still malfunction due to door or frame movement caused by environmental factors. Adjust the latch and deadbolt positioning if needed.

Regularly check for debris in the mortise and ensure that frame holes behind striking plates are clear to facilitate smooth bolt movement. Lubricate latch bolts, avoiding grease on internal mechanisms to prevent dust attraction.

Cylinders

Avoid oil lubricants on cylinders, as they attract dust. Use powdered graphite periodically for maintenance.

Lever Handles

Check backplate and rose fixings for tightness. Poorly maintained hardware can impede lock function. Ensure spindle grub screws are secure.

Pull Handles

Inspect pull handles for tight fixings. Loose handles can damage the door.

Emergency and Panic Exit Hardware

Regular inspections are vital for safety. Ensure ease of operation and adjust for any door or frame movement. Keep floor sockets clean to allow free movement of bolts. Light machine oil can be applied to pivot points.

Outside access devices (OADs) on fire exit doors should only be used for limited access to maintain their functionality.

Paintwork

Steel doors typically feature a powder coat or stainless steel finish. Clean as follows:

- General dirt: Use a non-abrasive cleaning solution diluted in hot water. Wipe with a wrung cloth to avoid soaking.
- Specific issues: Seek specialized advice for specific stains or problems.
- Surface damage: Touch up scratches with a compatible paint system

Care of Finishes

Corrosion often results from dirt and moisture on metal surfaces. In harsh environments, acidic or alkaline deposits can deteriorate finishes. Proper maintenance is essential for longevity.

Regularly dust surfaces with a soft, dry cloth, and occasionally clean with warm soapy water. Follow up with a quality wax polish to protect finishes. Avoid chemical sprays, abrasive cleaners, and materials that could damage surfaces.

- Electro-Plated Finishes - Clean with soapy water and a soft cloth, then dry.
- Powder Coating and 2-Pack Paint Finishes - Use a soft cloth and household furniture polish for cleaning; avoid industrial solvents.

Refinishing and On-Site Repairs

Remove all hardware before repainting. Never paint over hinges or locks. For minor dents, use car body filler and weatherproof paint.